



ELECTRONICS
DESIGN &
MANUFACTURING

Solution 4 + 4 *Quick Reference Guide*

ISSUE 1.10



Solution 4+4

Quick Reference Guide

Copyright © 1997 by Electronics Design & Manufacturing Pty Limited,
SYDNEY, AUSTRALIA

Document Part Number MA400Q

Document Issue 1.10

Printed 15 July 1997

This documentation is provided to suit *Solution 4+4* (CC400/LP400)

Firmware Revision 1.20 - 1.27

Hardware Revision D

Alarm Link Form - Software Version 1.20 - 1.27 = S4_V12

Copyright Notice

All rights reserved. No part of this publication may be reproduced, transmitted or stored in a retrieval system in any form or by any means, electronic, mechanical, photocopying, recording, or otherwise, without the prior written permission of Electronics Design and Manufacturing Pty Limited.

Trademarks

Throughout this document trademark names may have been used. Rather than put a trademark symbol in every occurrence of a trademark name, we state that we are using the names only in an editorial fashion and to the benefit of the trademark owner with no intention of infringement of the trademark.

Notice of Liability

While every precaution has been taken in the preparation of this document, neither Electronics Design & Manufacturing Pty Limited nor any of its official representatives shall have any liability to any person or entity with respect to any liability, loss or damage caused or alleged to be caused directly or indirectly by the information contained in this book.

Electronics Design & Manufacturing Pty Limited reserves the right to make changes to features and specifications at any time without prior notification in the interest of ongoing product development and improvement.

Introduction

Thankyou for choosing the *Solution 4+4* control panel for your installation. We are sure that you will find this system extremely flexible, reliable and easy to use.

Before using the system for the first time, we suggest that you read the section in this Quick Reference Guide called "Programming Using A Remote Codepad" to familiarise yourself with the basic programming methodology.

The Quick Reference Guide is supplied with the *Solution 4+4* to provide users with enough basic information to wire, configure and operate the system. Due to the systems many programmable features and options we suggest that you obtain the complete Installation Manual which provides detailed information on all system options and functions as well as detailed information on the numerous programming methods.

Programming

The programming options of this system are stored in a non volatile EPROM. This memory will hold all the relevant configuration and user specific data even during a total power loss.

The data retention time is as long as ten years without power, therefore no reprogramming will be required after powering the system down.

The data can be altered as many times as required without the need for any additional specialised equipment. This memory is laid out in numerous locations each of which holds the data for a specific function. In general, the entire programming sequence will consist of nominating the location then entering or altering the required data. You will repeat this procedure until all the data has been altered to suit your requirements. The factory default settings have been selected for Contact ID format.

Note: '15' is the maximum value that can be programmed into any location.

There are two programming modes. The Installer's Programming Mode and the Operators Programming Mode. Both modes have individual access codes and these two codes must always be programmed differently. The Master Code, as well as being able to arm and disarm the system gives access to the Operators Programming Mode. The Installer's Code only gives access to the Installer's Programming Mode and does NOT arm and disarm the system.

Programming of the *Solution 4+4* control panel can be carried out via any of the following four methods.

- System Codepad
- Hand Held Programmer (CC814)
- Programming Key (CC810)
- Alarm Link (Upload/Download) Software (CC816)

Note: For further information on the different programming options available for the *Solution 4+4*, refer to the Installation Manual (MA400I).

Programming Using A Remote Codepad

The system must be in a disarmed state with no flashing zone alarm memories, this can be achieved by entering the **MASTER CODE** followed by the **AWAY** button. The factory default Master Code is **2580**.

To access the Installer's Programming Mode, enter the four digit **INSTALLER CODE** followed by the **AWAY** button. The factory default Installer Code is **1234**. Three beeps will be heard and both the AWAY and the STAY indicators will flash simultaneously. If a long beep is heard, check the system for alarm memory. The combination of the MAINS and ZONE indicators will indicate the data stored in the first location (LOCATION 000).

Data Value	Zone 1 Indicator	Zone 2 Indicator	Zone 3 Indicator	Zone 4 Indicator	Zone 5 Indicator	Zone 6 Indicator	Zone 7 Indicator	Zone 8 Indicator	MAINS Indicator
1	✓								
2		✓							
3			✓						
4				✓					
5					✓				
6						✓			
7							✓		
8								✓	
9	✓							✓	
10									✓
11	✓								✓
12		✓							✓
13			✓						✓
14				✓					✓
15					✓				✓

Zone Indicators When Programming

Example

To move to a particular programming location, enter the location number required followed by the **AWAY** button. The data of the new location will now be displayed.

To move to the next location, press the **AWAY** button. This will step you to the next location and the data in that location will be displayed via the zone LED indicators.

If you press the **STAY** button without previously entering a location number, the system will step back one location. To change data in the current location, enter the new value followed by the **STAY** button. This will store the new data into the location and still leave you positioned at the same location.

To proceed to the next location, press the **AWAY** button. The next locations data will now be displayed.

To exit the Installer's Programming Mode, enter the command **960** followed by the **AWAY** button. Two beeps will be heard and the system will return to normal.

For a more detailed explanation, refer to the *Solution 4+4 Installation Manual (MA400I)*.

Quick Start

The following steps will enable you to use the *Solution 4+4* panel with the default values as set in the factory. The default settings allow the panel to communicate in Contact ID format.

1. Connect AC plug pack to the control panel.
2. Check the operation of the red overload LED (LD1) on the PCB. In normal operation the LED will not illuminate. The MAINS indicator will remain on as will the AWAY indicator. The unit is now in the armed state.
3. The back-up battery should now be connected.
4. Enter the default Master Code **2580** followed by the **AWAY** button. The AWAY indicator will extinguish. The panel is now in the disarmed state. Installer's Programming Mode can now be accessed.
5. Enter the factory default Installer Code **1234** followed by the **AWAY** button. The STAY and AWAY indicators will now flash simultaneously.
6. Enter the primary and secondary telephone numbers and the Subscriber ID Number.
7. Set the time for the test reports if this option is required. Any other programming changes required can also be made, otherwise the factory programming default settings will be used.
8. Enter command **960** followed by the **AWAY** button to exit Installer's Programming Mode. The panel will return to the unarmed state and is now ready for use.
9. Using a Master Code to set the date and time.
 - Enter **MASTER CODE** followed by **6** and the **AWAY** button.
 - Enter the day of the month, then the month, then the year, then the hour, then the minute using the format (DD, MM, YY, HH, MM).
 - Press the **AWAY** button when finished.

Zone Default Settings

The zone default settings are as listed in the table below.

Zone No	Zone Type
1	Delay-1
2 & 3	Handover
4	24 Hour

Note: The example given in this quick reference guide is a simplified description of how to configure the panel. This system offers many other programmable features which are described in detail in the *Solution 4+4 Installation Manual (MA400I)*.

Installer's Programming Commands

There are several commands that can be invoked to perform the functions as listed below. These commands only operate while you are in the Installer's Programming Mode. To invoke the command, enter in the corresponding numerical code then press the **AWAY** button.

<i>Command</i>	<i>Description</i>
958	Enable and Disable Zone Status Mode
959	Test Programming Key
960	Exit Installer's Programming Mode
961	Reset to Factory Default Settings (Contact ID Format)
962	Copy The Panel Memory To The Programming Key
963	Copy The Programming Key Data To The Panel Memory
964	Wipe Programming Key
965	Set Defaults For Domestic Dialling Reporting Format
966	Enable and Disable Automatic Stepping Of Locations During Programming
999	This Command Displays The Control Panel's "Software Version" Number When Using The Hand Held Programmer

Installers Programming Commands

Installer Code Functions

Installer Code functions are designed to allow the installer to perform various system tests without the need to know a Master Code.

The **INSTALLER CODE** is entered followed by a **FUNCTION** digit then the **AWAY** button to activate the particular mode.

INSTALLER CODE + **FUNCTION** + **AWAY**

These functions can only be carried out while the system is in the disarmed state.

<i>Function</i>	<i>Description</i>
0	Fault Analysis Mode
1	Reserved
2	Set Number Of Days Until The First Test Report
3	Event Memory Recall
4	Walk Test Mode
5	EDMSAT - Satellite Siren Service Mode
6	Initiate Modem Call
7	Turning Telephone Monitor Mode On and Off
8	Reserved
9	Send A Test Report

Installer Code Functions

Master Code Functions

Master Code functions are designed to allow those users that have the appropriate access level to perform certain functions of a supervisory level. These functions can only be carried out while the system is in the disarmed state.

MASTER CODE +
 FUNCTION +
 AWAY

<i>Function</i>	<i>Description</i>
0	Reserved
1	Changing and Deleting User Codes
2	Changing Domestic Phone Numbers
3	Event Memory Recall
4	Walk Test Mode
5	Fault Analysis Mode
6	Setting The Date and Time
7	Turning Day Alarm On/Off
8	Reset Latched Outputs
9	Initiate Modem Call

Master Code Functions

Fault Analysis Mode

There are various system faults that can be detected by *Solution 4+4*. When any of these are present the FAULT indicator will begin to flash and the codepad will beep once every minute. Hold the **5** button down for two seconds until two beeps are heard. The STAY and AWAY indicators will begin to flash in unison with the FAULT indicator. One or more zone indicators (1-8) will illuminate to indicate the current fault(s). Refer to the following table.

<i>Zone Indicator</i>	<i>Description</i>
1	Low Battery
2	Date and Time
3	Sensor Watch
4	Horn Speaker Disconnected
5	Reserved
6	E ² Fault
7	Reserved
8	Communications Failure

Fault Types

Hold Down Functions

Hold Down functions have been incorporated to allow easy activation of specific operations. When a button is held down for two seconds, two beeps will be heard and a particular function will operate. The functions are listed below.

<i>Function</i>	<i>Description</i>
AWAY	Arm The System In AWAY Mode
STAY	Arm The System In STAY Mode
0	Reserved
1	Horn Speaker Test
2	Bell Test
3	Strobe Test
4	Turning Day Alarm On and Off
5	Fault Analysis Mode
6	Initiate Modem Call
7	Reset latching Outputs
8	Codepad Beeper Tone Change
9	Initiate Test Report

Hold Down Functions

How To Test The Dialler

Telephone Monitor mode allows the codepad to be used for a visual representation of data transmissions between the control panel and the base station receiver. The dialling sequence is also shown in this mode.

The codepad will beep once every two seconds while Telephone Monitor Mode is turned on regardless of whether the system is in Installer's Programming Mode or normal operating mode. The first five zone indicators are used to display the progressive steps for a transmission to the base station receiver.

<i>Zone LED</i>	<i>Event</i>
1	Telephone Line Seized
2	Dialling Phone Number
3	Handshake Received
4	Data Is Being Transmitted
5	Kiss Off Received
None	Telephone Line Released

To Turn Telephone Monitor Mode On

1. Enter your **INSTALLER CODE** followed by **7** and the **AWAY** button.
Three beeps will be heard.

INSTALLER CODE + **7** + **AWAY**

To Turn Telephone Monitor Mode Off

1. Enter your **INSTALLER CODE** followed by **7** and the **AWAY** button.
Two beeps will be heard.

INSTALLER CODE + **7** + **AWAY**

Location 000 - 015

Primary Telephone Number

0	0	0	0	0	0	0	0	0	0	0	0	0	0	0	0	0
---	---	---	---	---	---	---	---	---	---	---	---	---	---	---	---	---

Location 016 - 031

Secondary Telephone Number

0	0	0	0	0	0	0	0	0	0	0	0	0	0	0	0	0
---	---	---	---	---	---	---	---	---	---	---	---	---	---	---	---	---

Location 032 - 047

Callback Telephone Number

0	0	0	0	0	0	0	0	0	0	0	0	0	0	0	0	0
---	---	---	---	---	---	---	---	---	---	---	---	---	---	---	---	---

Location 048

Dialling Format

- | | |
|-------------------------------------|---------------------------------------|
| 1 = Australian DTMF | 4 = International DTMF |
| 2 = Australian Decadic | 5 = Reversed Decadic |
| 3 = Alternate DTMF & Decadic (AUST) | 6 = Alternate DTMF & Reversed Decadic |

1

Location 049

Handshake Tone

- | | |
|-----------------------------------|---------------------------|
| 1 = HI-LO Handshake (Contact ID) | 4 = No Handshake Required |
| 2 = 1400 Hz (Ademco TX @ 1900 Hz) | 5 = Pager |
| 3 = 2300 Hz (Sescoa TX @ 1800 Hz) | |

1

Location 050

Transmission Format

- | | | |
|------------------------------|----------------------------|------------------|
| 1 = Contact ID | 6 = 4 + 1 Pulsed Expanded | 11 = Domestic |
| 2 = 4 + 2 Expressed | 7 = 3 + 1 Pulsed Universal | 12 = Basic Pager |
| 3 = 4 + 2 Pulsed | 8 = 3 + 1 Pulsed Expanded | 13 = Reserved |
| 4 = 4 + 2 Pulsed + Checksum | 9 = Reserved | 14 = Reserved |
| 5 = 4 + 1 Pulsed + Universal | 10 = Reserved | 15 = Reserved |

1

Location 051

Transmission Speed

- | | |
|------------------------|----------------------------|
| 1 = 1 Pulse / Second | 4 = 20 Pulses / Second |
| 2 = 10 Pulses / Second | 5 = 20 Pulses / Second FDL |
| 3 = 15 Pulses / Second | 6 = 40 Pulses / Second |

2

Location 052 - 055

Subscriber ID Number

0	0	0	0
---	---	---	---

Location 056 - 059

Installer Code

1	2	3	4
---	---	---	---

Location 060

Ring Count

- 15 = Answering Machine Bypass 1
 14 = Answering Machine Bypass 2 (New - Software Version 1.27 Onwards)

8

Location 061 - 100

User Codes

		Location 61 - 65		Location 66 - 70																
	User Code 1	<table border="1"><tr><td>2</td><td>5</td><td>8</td><td>0</td><td>8</td></tr></table>	2	5	8	0	8	User Code 2	<table border="1"><tr><td>15</td><td>15</td><td>15</td><td>15</td><td>0</td></tr></table>	15	15	15	15	0						
2	5	8	0	8																
15	15	15	15	0																
		Location 71 - 75		Location 76 - 80																
User Code 3	<table border="1"><tr><td>15</td><td>15</td><td>15</td><td>15</td><td>0</td></tr></table>	15	15	15	15	0	User Code 4	<table border="1"><tr><td>15</td><td>15</td><td>15</td><td>15</td><td>0</td></tr></table>	15	15	15	15	0	User Code 5	<table border="1"><tr><td>15</td><td>15</td><td>15</td><td>15</td><td>0</td></tr></table>	15	15	15	15	0
15	15	15	15	0																
15	15	15	15	0																
15	15	15	15	0																
		Location 86 - 90		Location 91 - 95																
User Code 6	<table border="1"><tr><td>15</td><td>15</td><td>15</td><td>15</td><td>0</td></tr></table>	15	15	15	15	0	User Code 7	<table border="1"><tr><td>15</td><td>15</td><td>15</td><td>15</td><td>0</td></tr></table>	15	15	15	15	0	User Code 8	<table border="1"><tr><td>0</td><td>15</td><td>15</td><td>15</td><td>1</td></tr></table>	0	15	15	15	1
15	15	15	15	0																
15	15	15	15	0																
0	15	15	15	1																

Location 101

Day Alarm Mask

- 1 = Zone 1
 2 = Zone 2
 4 = Zone 3
 8 = Zone 4

1

Location 102

Code Retries

6

Location 103

EOL Resistor Value

- | | | | |
|---------|---------|---------------|------------------------------|
| 1 = 1K | 5 = 3K9 | 9 = 10K | 13 = Reserved |
| 2 = 1K5 | 6 = 4K7 | 10 = 12K | 14 = Reserved |
| 3 = 2K2 | 7 = 5K6 | 11 = 22K | 15 = Split EOL (3K3/6K8) For |
| 4 = 3K3 | 8 = 6K8 | 12 = Reserved | 4 Zones + 4 Tamper Zones |

4

Location 104 - 151

Zones

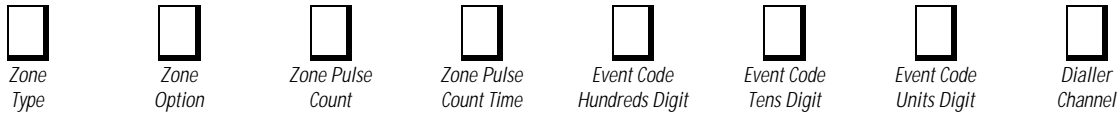
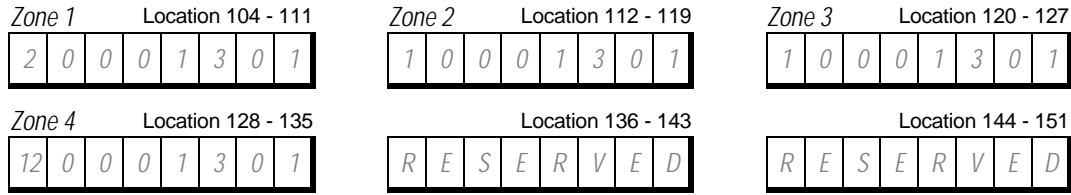

Each zone contains eight locations which are divided into two groups of four. The first four locations determine how the zone operates, while the second four locations contain the dialler reporting information.

Zone Types

There are thirteen different zone types to choose from. Each zone can be programmed as any of the zone types listed in the table below.

Zone Type	Description	Zone Type	Description
0	Instant	8	Delay-1 + Isolated In STAY Mode 1
1	Handover	9	Delay-2 + Isolated In STAY Mode 1
2	Delay-1	10	Reserved
3	Delay-2	11	Keyswitch
4	Reserved	12	24 Hour Burglary
5	Reserved	13	24 Hour Fire
6	Instant + Isolated In STAY Mode 1	14	Chime Only
7	Handover + Isolated In STAY Mode 1	15	Zone Not Used

Zone Options

Zone Option	Description
1	Lockout Siren
2	Lockout Dialler
4	Silent Alarm
8	Sensor Watch

Zone Pulse Count Settings

The pulse count settings for each zone can be programmed between 0 - 15.

Zone Pulse Count Time

Zone pulse count time is the time frame or period over which the number of pulses must register.

20 ms Loop Response Time Zone Pulse Count Time		150 ms Loop Response Time Zone Pulse Count Time	
0	0.5 Second	8	20 Seconds
1	1 Second	9	30 Seconds
2	2 Seconds	10	40 Seconds
3	3 Seconds	11	50 Seconds
4	4 Seconds	12	60 Seconds
5	5 Seconds	13	90 Seconds
6	10 Seconds	14	120 Seconds
7	15 Seconds	15	200 Seconds

Zone Descriptions

Use this table as a reference to indicate what each zone is connected to.

Zone	Description	Tamper Zone	Description
1		1	
2		2	
3		3	
4		4	

Location 152 - 153

Bypass Codes (Zones 1 To 4)

9	9
---	---

Location 154 - 155

Trouble Codes (Zones 1 To 4)

9	9
---	---

Location 156 - 159

Codepad Duress

1	2	1	1
---	---	---	---

Location 160 - 163

Codepad Panic

1	2	0	1
---	---	---	---

Location 164 - 167

Access Denied (Code Retries)

4	2	1	1
---	---	---	---

Location 168 - 161

AC Fail

3	0	1	1
---	---	---	---

Location 172 - 175

Low Battery

3	0	9	1
---	---	---	---

Location 176 - 179

Sensor Watch

3	0	7	1
---	---	---	---

Location 180 - 181

Open/Close

8	9
---	---

Location 182 - 185

Test Reporting Time

Location 182
Location 183
Location 184
Location 185

Actual Hour Of The Day (Tens Digit)
Actual Hour Of The Day (Units Digit)
Repeat Interval In Days
Expansion Code For 4+2 Format

0	0	0	9
---	---	---	---

Location 186 - 209

Output Configurations

	Location 186 - 191		Location 192 - 197		Location 198 - 203
<i>Output 1</i>	1 14 0 0 0 0	<i>Strobe</i>	2 0 1 0 0 0	<i>Relay</i>	1 15 1 0 0 0

Location 204 - 209

Codepad 0 12 2 1 0 1

Event Type	Polarity	Time Base	Time Multiplier

Location 210 - 211

Entry Timer 1

Location 210 Increments Of 1 Second (0 - 15 Sec's)
Location 211 Increments Of 16 Seconds (0 - 240 Sec's)

10	0
----	---

Location 212 - 213

Entry Timer 2

Location 212 Increments Of 1 Second (0 - 15 Sec's)
Location 213 Increments Of 16 Seconds (0 - 240 Sec's)

4	1
---	---

Location 214 - 215

Exit Time

Location 214 Increments Of 1 Second (0 - 15 Sec's)
Location 215 Increments Of 16 Seconds (0 - 240 Sec's)

12	3
----	---

Location 216 - 217

Entry Guard Time For STAY Mode

Location 216 Increments Of 1 Second (0 - 15 Sec's)
Location 217 Increments Of 16 Seconds (0 - 240 Sec's)

12	3
----	---

Location 218 - 219

Sensor Watch Time

Location 218 Increments Of Days (Tens Digit)
Location 219 Increments Of Days (Units Digit)

0	0
---	---

Location 220 <i>Codepad Lockout Time</i>	Location 220	Increments Of 10 Seconds	0
Location 221 <i>Siren Run Time</i>	Location 660	Increments Of Minutes (0-15)	10
Location 222 <i>Siren Sound Rate (Slow <-Sound-> Fast)</i>			7
Location 223 <i>Swinger Shutdown Count</i>			0
Location 224 <i>Dialler Options 1</i>		1 = Enable Dialler Reporting Functions 2 = Enable Remote Arming Via The Telephone 4 = Enable Upload/Download Via Alarm Link 8 = Terminate "Alarm Link" Session On Alarm	5
Location 225 <i>Dialler Options 2</i>		1 = Send Open/Close Reports Only If A Previous Alarm Has Occurred 2 = Reserved 4 = Send Open/Close Reports When In STAY Mode 8 = Delay Siren Until Transmission Complete	0
Location 226 <i>System Options 1</i>		1 = Enable Forced Arming 2 = Enable EDM Smart Lockout 4 = Enable Monitoring Of Horn Speaker 8 = Enable Horn Speaker Beeps For Remote Control Operation	1
Location 227 <i>System Options 2</i>		1 = Enable Radio Key/Keyswitch Interface or Night Arm Station 2 = Enable Handover Delay To Be Sequential 4 = Enable Codepad Panic To Be Silent 8 = Enable Codepad Tamper To Be Silent	2
Location 228 <i>System Options 3</i>		1 = Reserved 2 = Reserved 4 = Ignore AC Fail 8 = Enable Pulse Count Handover	0
Location 229 <i>Consumer Options 1</i>		1 = Send Test Reports Only If The System Is Armed 2 = Enable Operation Of Siren & Strobe In STAY Mode 4 = Enable Answering Machine Bypass Only When Armed 8 = Enable Codepad Extinguish Mode	2
Location 230 <i>Consumer Options 2</i>		1 = Reserved 2 = Enable Single Button Arming In AWAY, STAY Mode 1 and STAY Mode 2 4 = Enable Single Button Disarming From STAY Mode 1 and STAY Mode 2 8 = Enable Alarm Memory Reset On Disarm	0
Location 900 <i>Disable Factory Default</i>		0 = Defaulting Enabled 15 = Defaulting Disabled	0
Location 901 - 904 <i>System Time</i>	Location 901 Location 902 Location 903 Location 904	Hour Of The Day (Tens Digit) Hour Of The Day (Units Digit) Minute Of The Day (Tens Digit) Minute Of The Day (Units Digit)	0 0 0 0

Connections For Split EOL Resistors For 4 Burglary Zones and 4 Tamper Zones

Enable 4 Burglary and 4 x 24 Hour Tamper Zone Operation Using (3K3/6K8) Configuration Using N/C Switches.

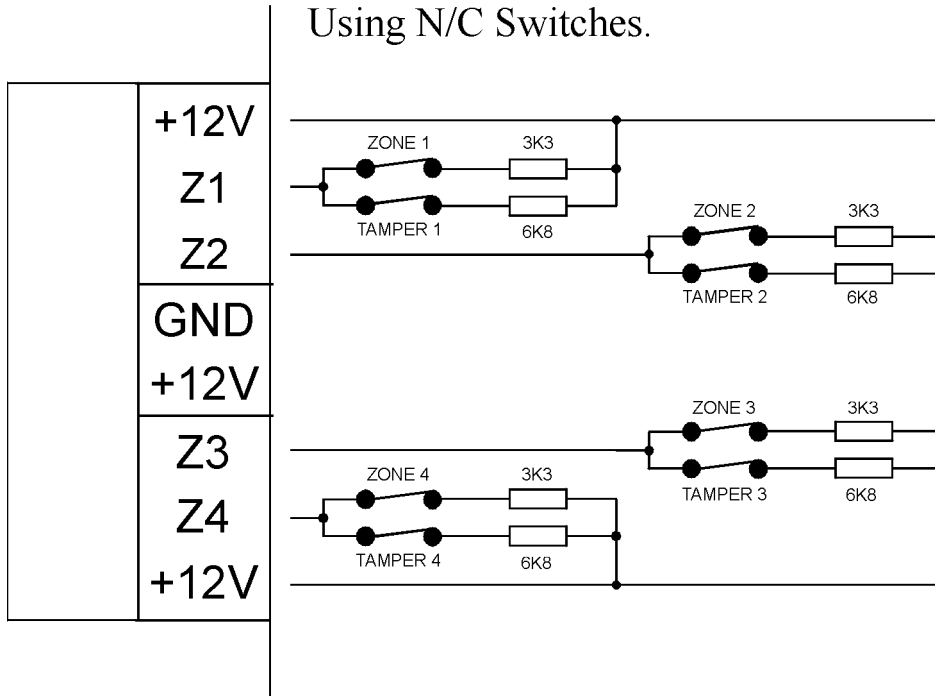

Wiring Diagram For Keyswitch Zone

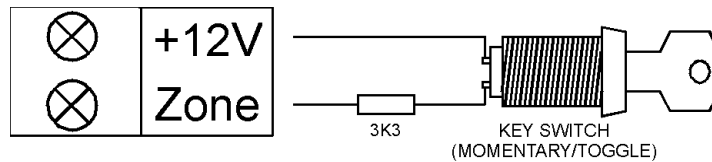

Wiring Diagram

Solution 4+4

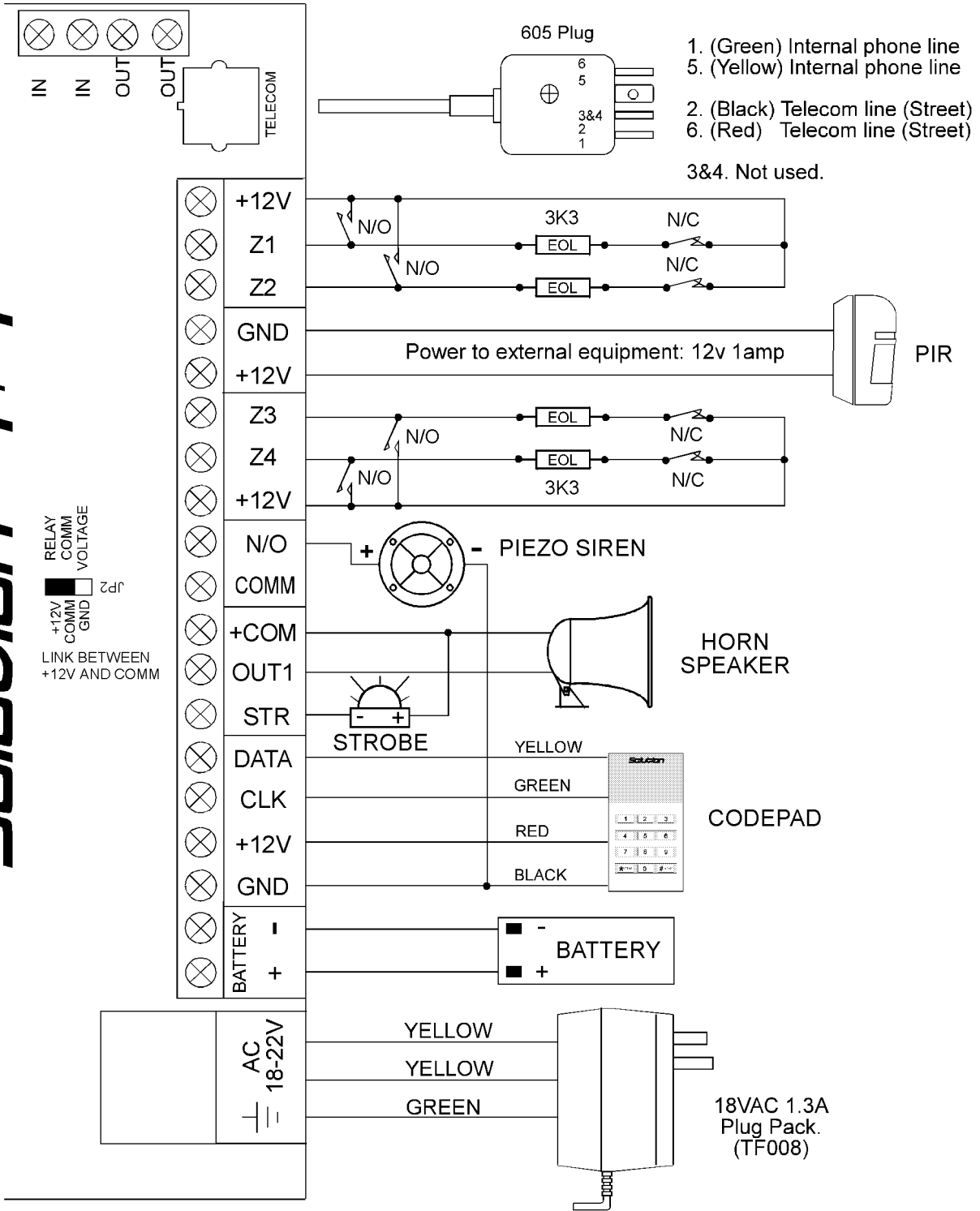

Component Overlay

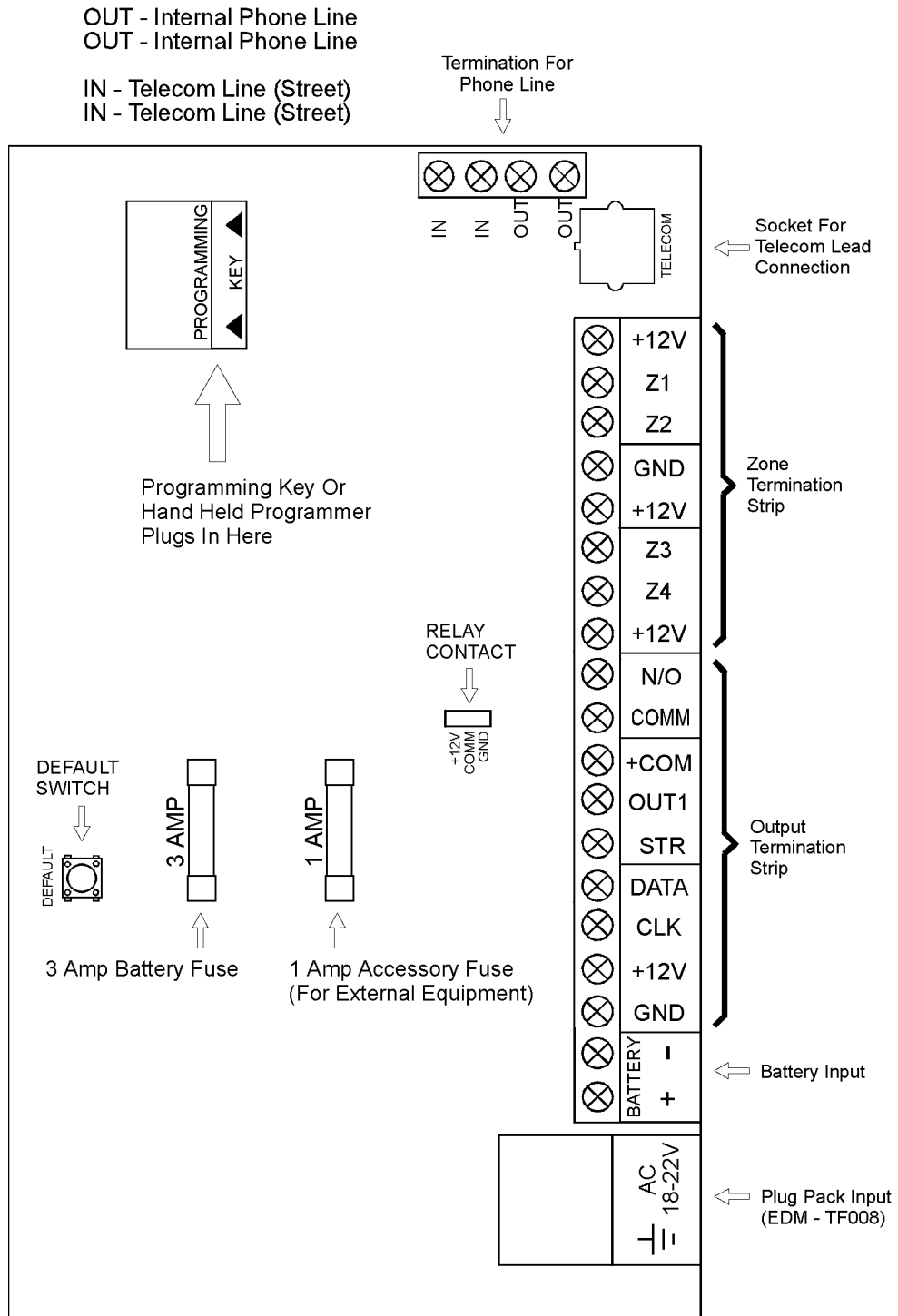

Dear Customer,

This Quick Reference Guide is supplied as a very limited document intended only to provide basic installer information. With this information you should be able to make the equipment operational in its simplest form provided you already have a basic understanding of the product. Installers who intend to make repeated installations are urged to purchase the full 200+ page installation manual which contains a wealth of information, diagrams and details the many outstanding features and benefits of the product.

Due to the size of this manual it is no longer practical for it to be included with every panel purchase. The cold hard facts are if the installation manual were to be included then the basic panel purchase price would increase to cover the extra costs.

The savings in panel costs will be multiplied with every new purchase and the benefits of having a detailed reference manual will save you countless dollars during your installation and service activities. Our environment also benefits from this policy as many installers would simply discard the surplus manuals. The cost of their disposal to the community, the trees required to produce the manuals in the first place and even the increased packaging costs all of which you the customer would be paying for.

Our surveys have found that 95% of installers are repeat product users and that there is nothing to be gained by having to pay for a manual with every panel. Instead we have made the installation manual a tool which is tax free to purchase and 100% tax deductible as a cost incurred in earning income.

It is obvious that the advantages of one manual for one installer greatly outweigh the disadvantages of not supplying an installation manual with every panel. I hope that this brief explanation shows that our intent is to save you money while still maintaining a superior standard of technical documentation.

Yours Sincerely

Meinrad Formosa

Managing Director



Electronics Design & Manufacturing Pty Limited

25 Huntingwood Drive
Huntingwood NSW 2148
Australia

A.C.N. 002 907 271

Phone: +612 9672 1777
Facsimile: +612 9672 1717
email: edm@edm.com.au
